



Product Name: External One Port GNSS Antenna

Part Number: EG-6AB-ES-A01

Features:

- Support GPS L1 / GLONASS L1/ GPS L2 Bands
- Excellent Out of Band Rejection, Up to 60dB
- 30dB Active Peak Gain
- Customizable Cables and Connectors
- RoHS & REACH Compliant

Applications:

- Automotive Navigation
- For all GNSS applications with networking such as sensor, sonar multi-function gauge, etc.

External One Port GNSS Antenna

MODEL: EG-6AB-ES-A01

Rev.A

I. Specifications:

Items	Specifications		
Passive Antenna Performance			
Application Bands	GPS L2	GPS L1	GLONASS L1
Frequencies (MHz)	1227	1575.42	1602
Efficiency (%)	6.78	43.95	29.04
Average Gain (dBi)	-11.69	-3.57	-5.37
Peak Gain (dBi)	-11.69	2.48	0.69
Axial Ratio	1.29	2.16	2.38
V.S.W.R	< 2		
Return loss (dB)	< -10		
Test Condition	Free Space		
Impedance (Ω)	50		
Polarization	R.H.C.P. (Right-Handed Circular Polarization)		
Active Antenna Performance			
Application Bands	GPS L2	GPS L1	GLONASS L1
Frequencies (MHz)	1227 \pm 5	1575.42 \pm 1.023	1602 \pm 5
Gain (dB)	35 Typ.	32 Typ.	32 Typ.
Noise Figure (dB)	3.0 Typ.		
Operation Voltage (V)	3.3 ~ 5.0		
Current Consumption (mA)	19 \pm 2		
Output Impedance (Ω)	50		

© Unictron Technologies Corp.
All specifications subject to change without notice.

Out of Band Rejection				
Application Bands	GPS L2		GPS L1 GLONASS L1	
Frequencies (MHz)	1340 ~ 1520	1650 ~ 3000	600 ~ 1100	1340 ~ 1520
Out of Band Rejection (dB)	62	71	59	59
ESD Protection	+/- 8 KV (direct discharge) +/- 15KV (air discharge)			
Mechanical				
Dimension (mm)	φ 80.0(D) x 90.0(L) x 25.4(H)			
Waterproof	IP67			
Cable / Length	H-100 / 5 meters			
Connector	SMA (Male)			
Environmental Conditions				
Operation Temperature (°C)	-40 ~ +85			
Storage Temperature (°C)	-40 ~ +85			
Relative Humidity	95% non-condensing			

II. Passive Electrical Properties:

S11 (dB)

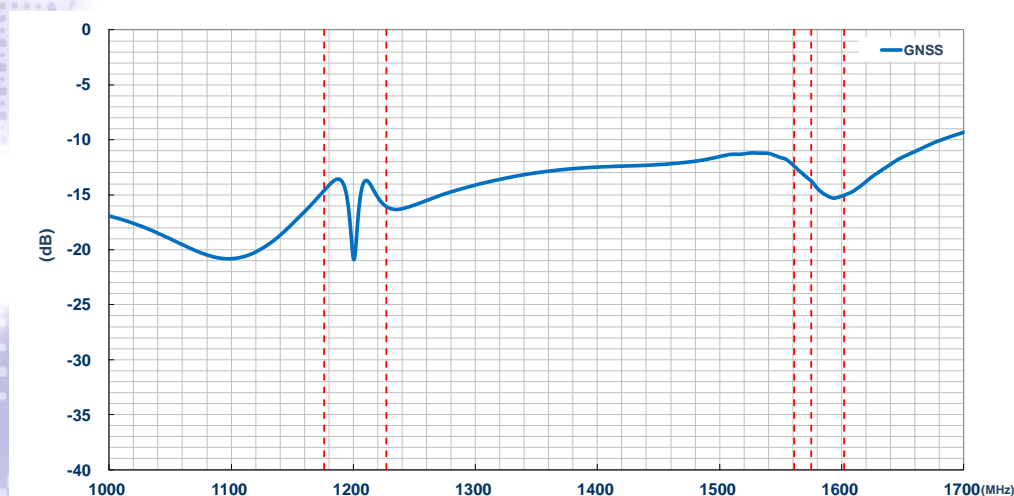

Efficiency (%)

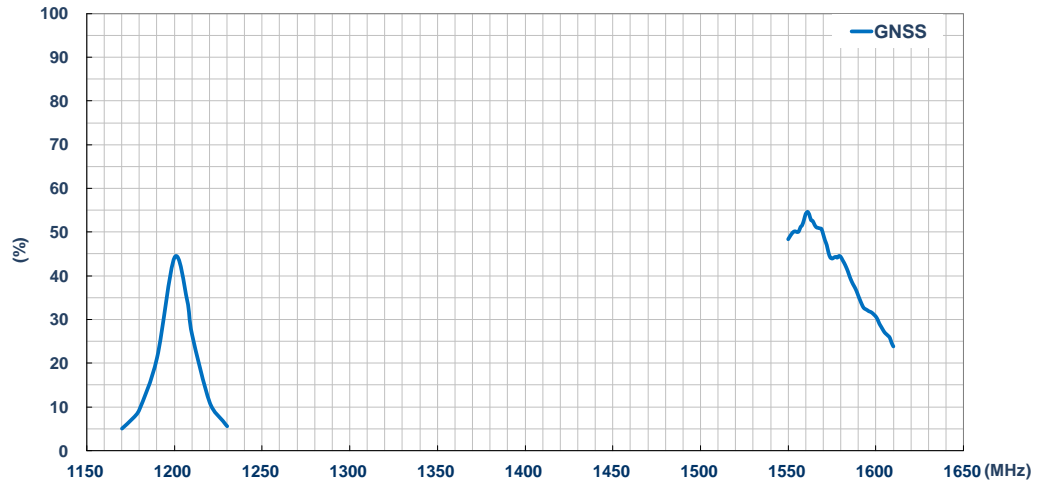

Average Gain (dBi)

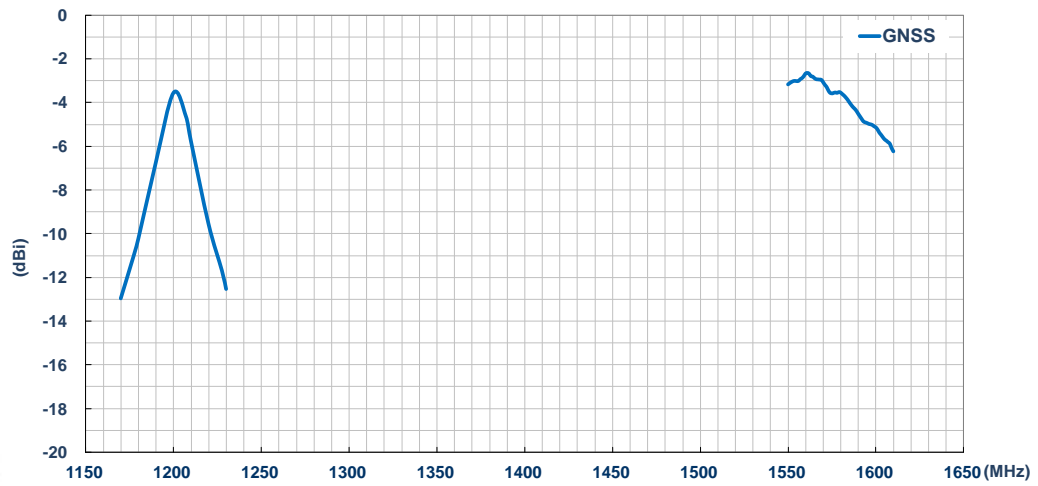

Peak Gain (dBi)

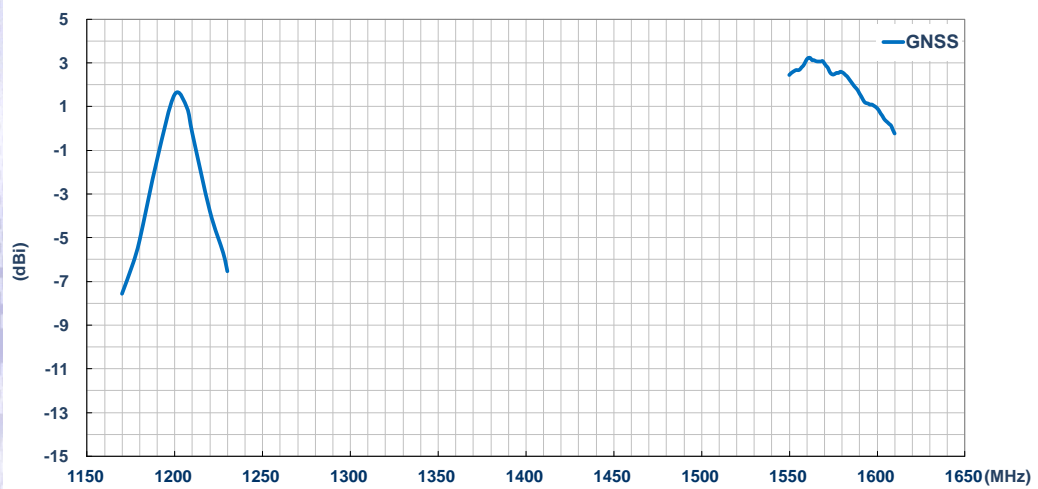

III. Active Electrical Properties:

Noise Figure & Gain (dB)

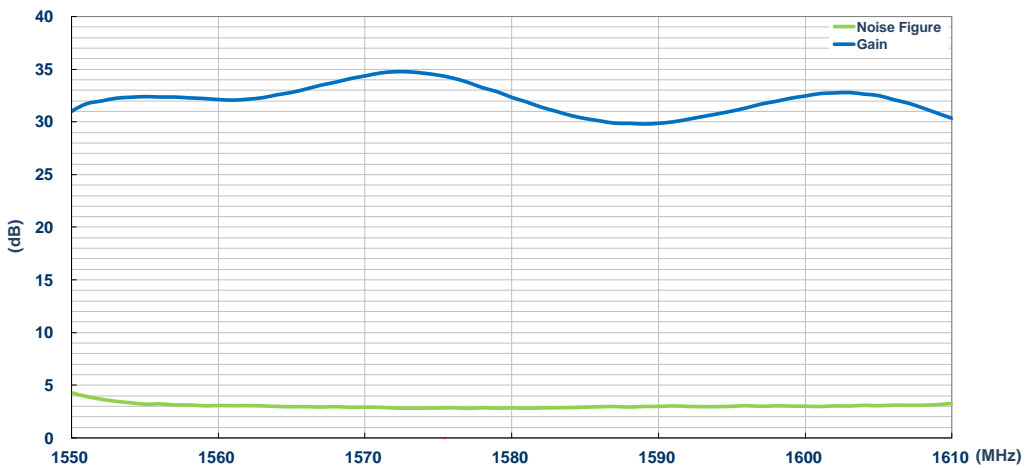
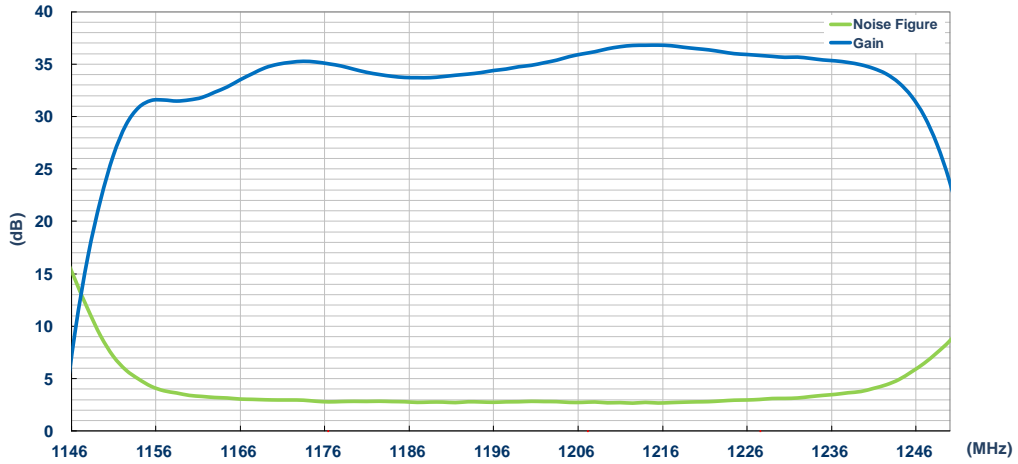

Out of Band Rejection (dB)

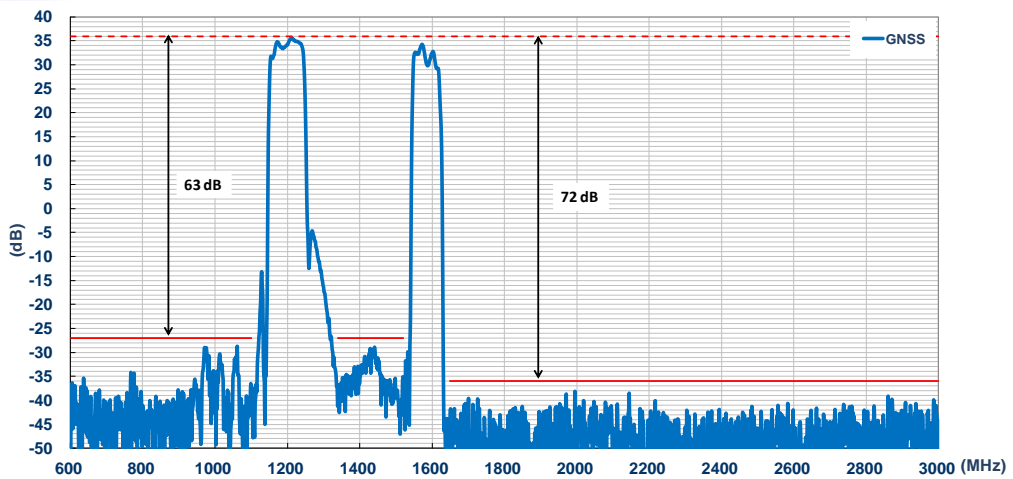

© Unictron Technologies Corp.
All specifications subject to change without notice.

IV. Antenna Radiation Pattern Measurement:

The antenna radiation patterns are measured in 3D Anechoic Chamber. The measurement setup is as show below,

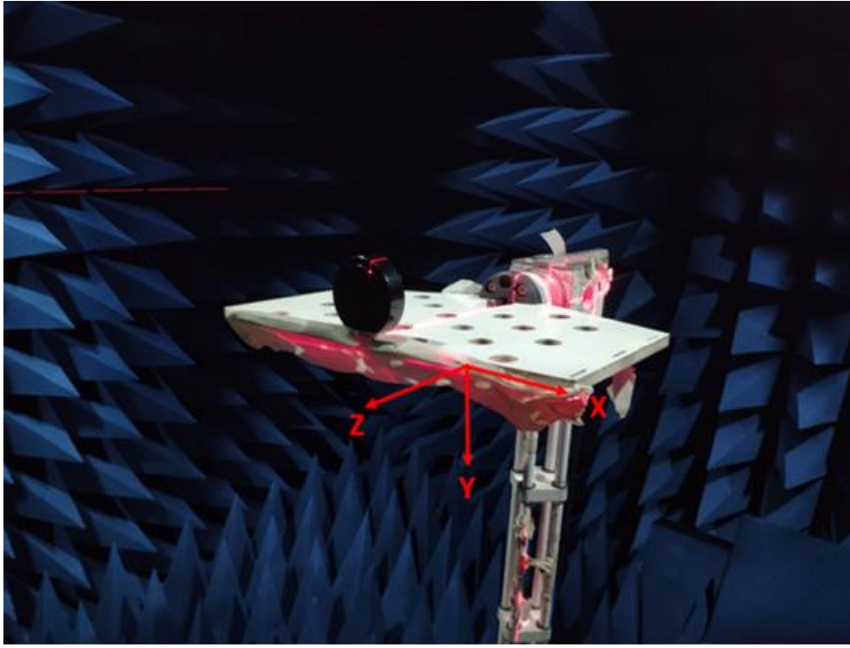

© Unictron Technologies Corp. All specifications subject to change without notice.

A) 2D Radiation Pattern:

X-Y Plane

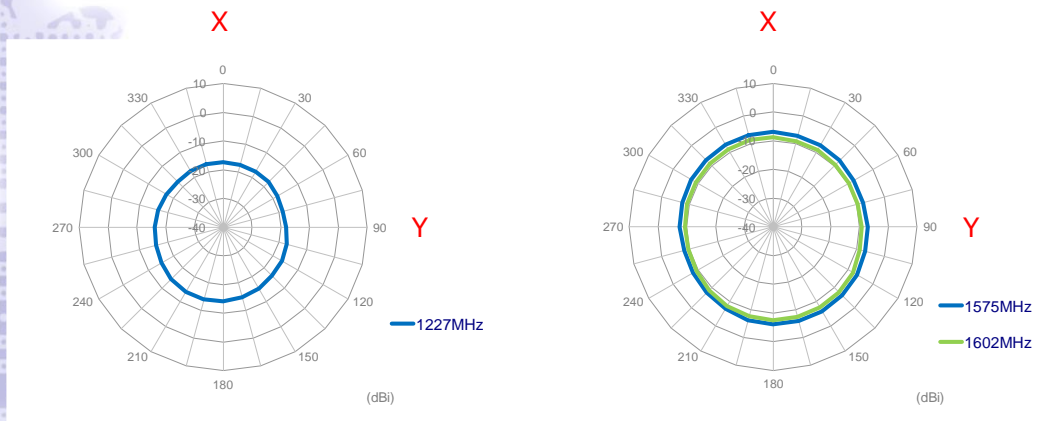

X-Z Plane

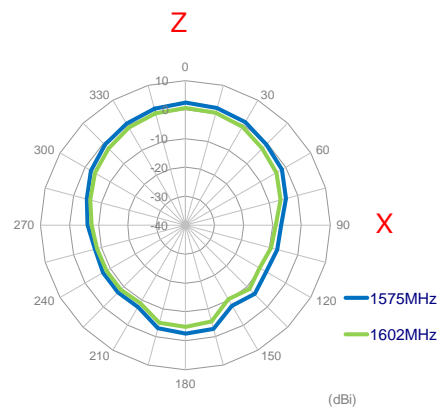
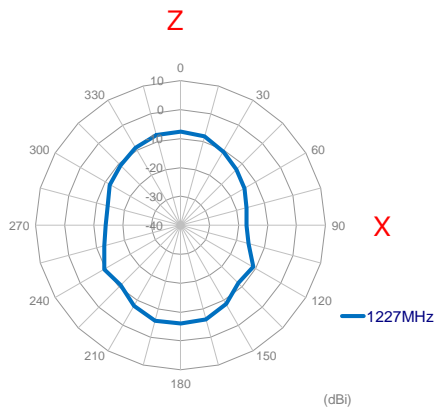

Y-Z Plane

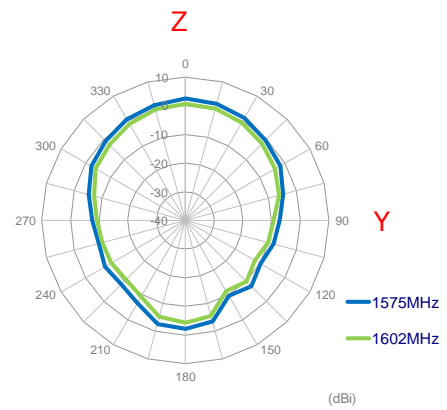
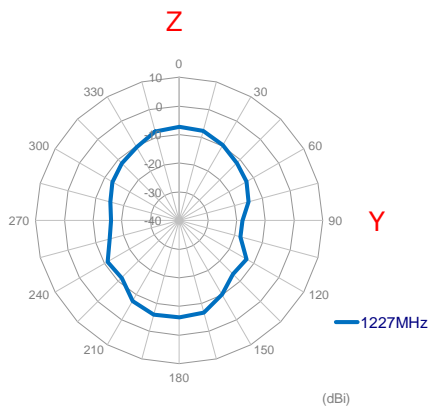

B) 3D Radiation Pattern:

1227MHz

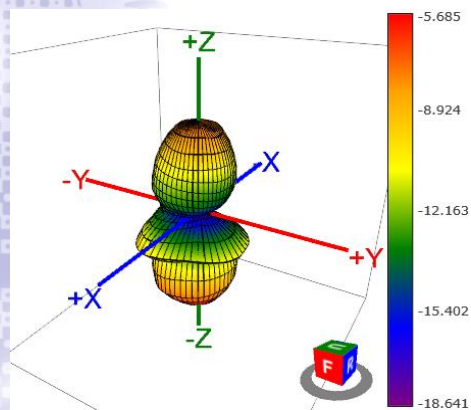

1575.42MHz

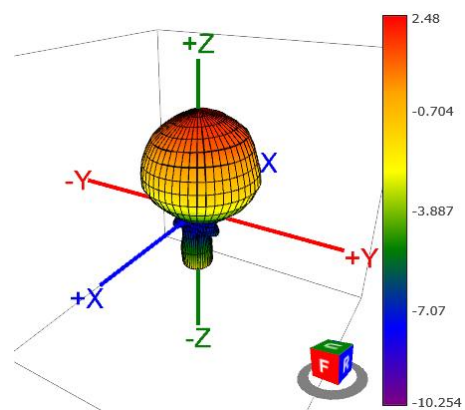

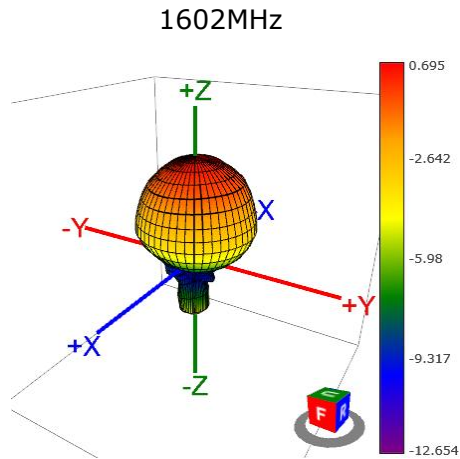

V. Mechanical Drawing (Unit:mm):

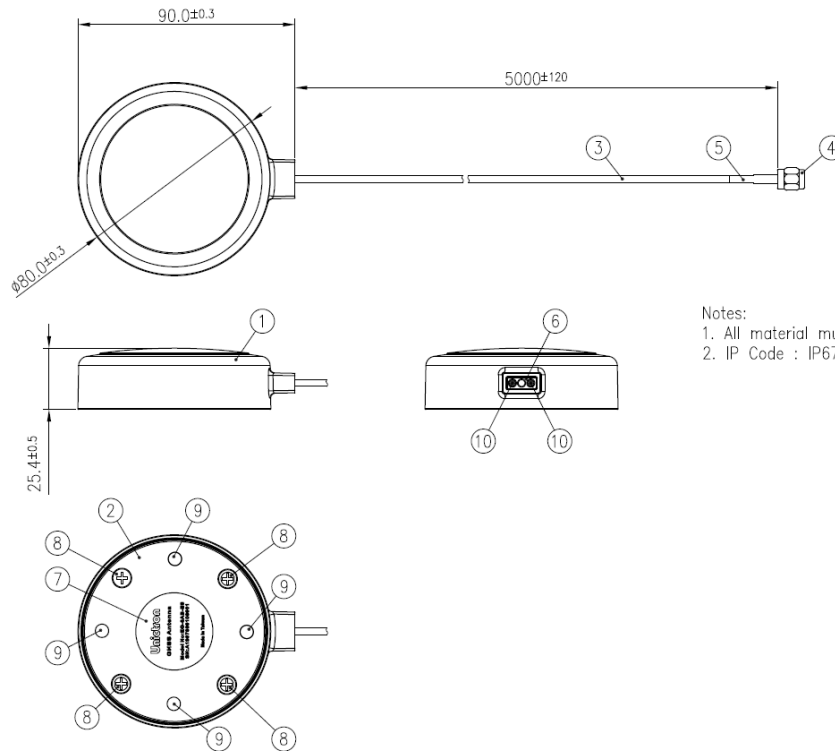

10	Rubber stopper	EPDM	Black	2
9	Slip Rubber	Silicone	Black	4
8	Screw	Stainless Steel	Cr	4
7	Label	PET	Silver	1
6	Cable Rubber	EPDM	Black	1
5	Heat Shrink Tube	EVA	Black	1
4	SMA(M) Connector	Brass	Au Plated	1
3	Cable H-100	PVC	Black	1
2	Bottom Base	Zinc Alloy	Ni Plated	1
1	Top Housing	PC+ABS	Black	1
No	NAME	MATERIAL	FINISH	QTY